



EWELLIX

# EWELLIX Linear Actuators

CAT

User Manual

We pioneer motion

**SCHAEFFLER**



# Contents

1	About the manual.....	5
1.1	Information in this user manual.....	5
1.2	Symbols .....	5
1.3	Signs.....	5
1.4	Legal notices .....	5
1.5	Liability.....	6
1.6	Availability .....	6
1.7	Images .....	6
2	General safety regulations .....	6
2.1	Intended Use.....	6
2.2	Non-intended Use .....	6
2.3	Qualified personnel.....	7
2.4	Protective equipment .....	7
2.5	Hazards.....	7
2.6	Safety regulations.....	8
2.6.1	Commissioning.....	8
2.6.2	Operation .....	8
2.6.3	Transport and storage.....	8
2.6.4	Maintenance and Repairs .....	8
3	Scope of delivery.....	9
3.1	Check for transport damage.....	9
3.2	Check for defects .....	9
4	Product description.....	9
4.1	Attachment Options.....	10
5	Transport and storage .....	10
6	Mounting .....	10
6.1	CAT32B, CAT33, CAT33H installation .....	11
7	Commissioning .....	12
8	Operation .....	12
9	Troubleshooting .....	12
10	Maintenance .....	13
11	Disposal .....	13
12	Technical data .....	13
12.1	Duty Factor .....	14
12.2	Circuit Diagrams .....	17
12.3	Two-channel Quadrature Encoder E2.....	18
12.4	Declaration of incorporation.....	19
13	Replacement parts and accessories.....	20

13.1	Replacement parts .....	20
13.2	Accessories .....	20

# 1 About the manual

## 1.1 Information in this user manual

This manual provides important information on how to work with the device safely and efficiently.

The manual is part of the device, must always be kept in the device's direct proximity and should be available for personnel to read at any time. All personnel working with the device must read and understand this manual before starting any work. Strict compliance with all specified safety notes and instructions is a basic requirement for safety at work.





Moreover, the accident prevention guidelines and general safety regulations applicable at the place of use of the device must also be complied with.

## 1.2 Symbols

Safety precautions are identified by symbols and signal words as shown. The signal words indicate the severity of the hazard and the chance it could occur. Follow these safety precautions and act cautiously in order to avoid accidents, personal injury and damage to property.

The warning and hazard symbols are defined in accordance with ANSI Z535.6-2011.





### 1.1 Warning and hazard symbols

Signs and descriptions	
 <b>DANGER</b>	In case of non-compliance, death or serious injury will occur.
 <b>WARNING</b>	In case of non-compliance, death or serious injury may occur.
 <b>CAUTION</b>	In case of non-compliance, minor or moderate injury may occur.
 <b>NOTICE</b>	In case of non-compliance, damage or malfunctions in the product or the adjacent construction may occur.

## 1.3 Signs

The warning, prohibition, and mandatory signs are defined in accordance with DIN EN ISO 7010 or DIN 4844-2.

### 1.2 Warning, prohibition, and mandatory signs

Signs and descriptions	
	General warning
	Electrical voltage warning
	Observe the manual
	General mandatory sign

## 1.4 Legal notices

The information in this manual reflects the status at the time of publication.

Unauthorized modifications to or improper use of the product are not permitted. Schaeffler accepts no liability in these cases.

## 1.5 Liability

In any case, the owner or the operator of the device is liable for its proper functioning if the device is improperly installed, maintained or repaired by persons who are not part of the Schaeffler Service department, or if the device is used in a manner that does not correspond to its intended use.

Schaeffler shall not be liable for any damage resulting from failure to observe these instructions. These instructions are not to be considered as an extension of the warranty conditions and liability conditions set out in Schaeffler's Terms and Conditions of Sale and Delivery.

The product is not subject to labeling requirements according to CE Directives or EMC Directives. The required EMC measures must be implemented on the end product by the manufacturer of the end product, taking into account the installation conditions, wiring and control, and must be checked in accordance with the intended use.

Compliance with these regulations is the responsibility of the manufacturer of the machine or system.

## 1.6 Availability



A current version of these instructions is available at:

<https://www.schaeffler.de/std/2226>

Ensure that this manual is always complete and legible and is available to all persons engaged in transporting, fitting, dismantling, commissioning, operating, or maintaining the product.

Keep the manual in a safe place for immediate reference.

## 1.7 Images

The images in this manual may be schematic representations and may differ from the delivered device.

# 2 General safety regulations

## 2.1 Intended Use

The actuator is only intended for use in the following situations:

- Axial loads
- Indoor applications
- Ambient temperature range from -20 °C to +50 °C (-5 °F to +122 °F)
- Intermittent use

## 2.2 Non-intended Use

The device must not be operated in potentially explosive atmospheres.

Do not use the device to lift people.

## 2.3 Qualified personnel

Operator duties:

- Ensure that only qualified and authorized personnel carry out the activities described in these instructions.
- Ensure that personal protective equipment is used.

Qualified personnel meet the following criteria:

- Product knowledge, e.g. by receiving training on how to use the product
- are fully familiar with the contents of this manual and, in particular, with all of the safety instructions
- are familiar with the relevant country-specific regulations

## 2.4 Protective equipment

For certain work on the product, suitable protective equipment must be worn. Personal protective equipment consists of:

 3 Required personal protective equipment

Personal protective equipment	Mandatory signs in accordance with DIN EN ISO 7010
Protective gloves	
Safety shoes	
Eye protection	

## 2.5 Hazards

### Danger to life caused by electric current

Touching live parts poses an immediate danger to life. Damage to insulation or individual components can also pose a danger to life. Therefore, observe the following:

- Work on the electrical system may only be carried out by electrically skilled persons.
- Disconnect the system from the power supply before performing any work on the electrical system.
- Before maintenance, cleaning, or repair work, disconnect the power supply and secure it against reconnection.

### Property damage due to exceeded load limit

- Only operate the actuator within the specified load limits

### Property damage due to load

- Always apply load to the actuator centrally
- Only operate the actuator within the specified load limits

### Property damage due to overheating

- Reduce time running under load
- Extend rest time

## 2.6 Safety regulations

The following safety regulations must be observed when working with the product. You can find further information on dangers and specific instructions in other chapters, including those entitled Installation, Commissioning, Operation, and Maintenance.

### 2.6.1 Commissioning

Only qualified personnel may start up the system.

Disconnect the power supply to the drive before performing installation or maintenance work.

Ensure that the drive is not under load or voltage before installation or maintenance work is performed.

Use suitable safety equipment when installing or maintaining the drive.

The power supply must comply with the technical specifications.

### 2.6.2 Operation

Exceeding the load limits of the actuator is prohibited. This can lead to serious injuries and material damage. The load limits specified in the technical data need to be observed.

Avoid moving the actuator to the mechanical end position. Repeatedly moving the actuator to the mechanical end position can damage it or shorten its operating life.

The motor and surrounding components can become hot under high loads and during a high duty cycle.

Do not operate the brake separately when the actuator is under load.

### 2.6.3 Transport and storage

The product may only be transported and stored in its original packaging and under the permissible ambient conditions, see *Technical data*.

#### Damage due to improper transport

Proceed with caution when unloading the packaged goods, during delivery, and during transport to the destination. Observe the symbols and instructions on the packaging. Do not remove the product from the packaging until immediately before installation.

### 2.6.4 Maintenance and Repairs

Maintenance work and repairs may only be carried out by qualified personnel.

Disconnect the power supply to the drive before performing installation or maintenance work.

Ensure that the drive is not under load or voltage before installation or maintenance work is performed.

Use suitable safety equipment when installing or maintaining the drive.

## 3 Scope of delivery

- Actuator
- User manual
- optional: motor
- optional: attachment

### 3.1 Check for transport damage

1. Check the product immediately upon delivery for any damage during transit.
2. Report any damage during transit promptly as a complaint to the carrier.

### 3.2 Check for defects

1. Check the product immediately upon delivery for any visible defects.
2. Report any defects promptly to the distributor of the product.
3. Do not put damaged products into operation.

## 4 Product description

The modular concept of EWELLIX linear actuator CAT simplifies the replacement of critical components such as motors, gearboxes, spindles, or attachments. Customer-specific linear actuators can easily be assembled from standard components to reduce expenses. Thanks to its flexibility, the CAT series is suitable for an endless number of applications.

The CAT32B, CAT33 and CAT33H actuators are available in the following designs:

- DC: 12 V, 24 V
- AC: 120 V, 230 V, 400 V
- 5 types of front attachment
- 4 types of rear attachment
- Encoder for digital feedback signal

## 4.1 Attachment Options

### 1 Attachment options

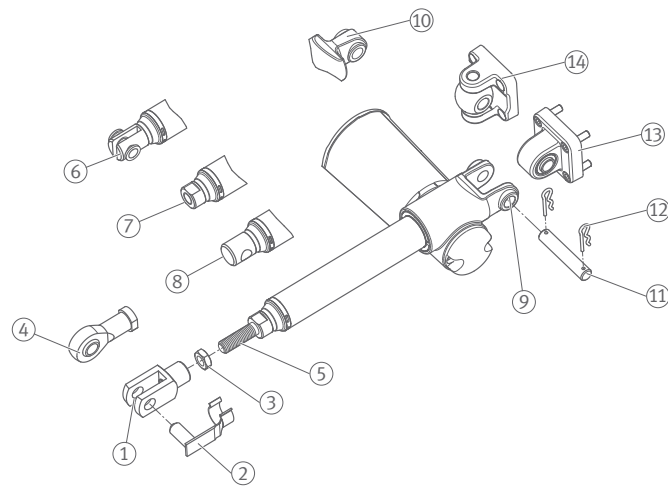

001C34D1

1	Front attachment, clevis 576-32	2	Safety pin for 576-32
3	Lock nut M12	4	Front attachment, rod end 575-32
5	Actuator front attachment G3	6	Actuator front attachment G5
7	Actuator front attachment G4	8	Actuator front attachment G1/G2
9	Actuator rear attachment A1/ A2	10	Actuator rear attachment K1/ K2
11	Mounting rod	12	Safety pin
13	Rear attachment, single bracket 580-32	14	Rear attachment, universal connection 582-32

## 5 Transport and storage

Observe the safety regulations for transport.

Observe the safety regulations for the storage.

## 6 Mounting

The surface the actuator is attached to must be able to withstand the force exerted by the actuator.

**!** If the actuator is ordered without a motor, make sure that the maximum dynamic torque on the worm screw does not exceed 0.3 Nm.

When attached, the maximum angle between the actuator and the rear attachment must not exceed 30°.

2 Maximum admissible attachment angle

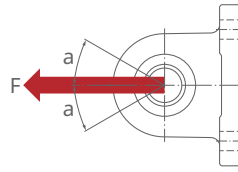

001C33F3

a	°	Max. admissible attachment angle 30°
F	N	Force

Make sure that the force exerted on the attachments is always centered on the actuator.

3 Force applied to the actuator always centered

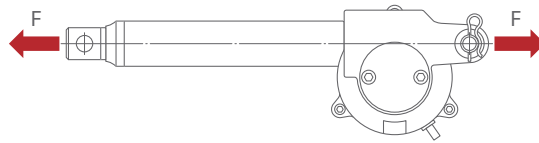

001C33F5

F	N	Force
---	---	-------

## 6.1 CAT32B, CAT33, CAT33H installation

4 CAT33, CAT32B, and CAT33H installation

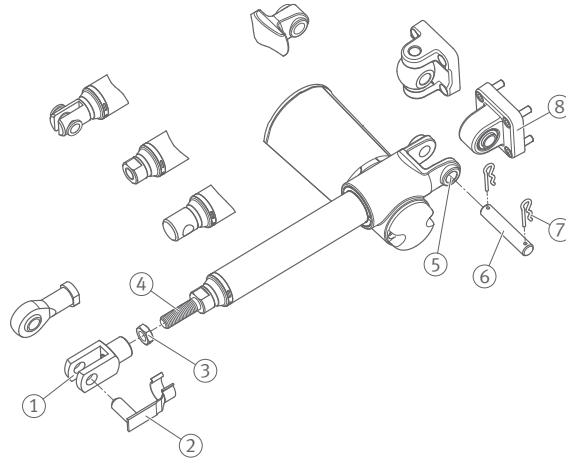

001C37FB

1	Front attachment, clevis 576-32	2	Safety pin for 576-32
3	Lock nut M12	4	Front attachment, thread
5	Actuator rear attachment A1/ A2	6	Mounting rod
7	Safety pin	8	Rear attachment, single bracket 580-32

1. Screw the lock nut (3) onto the actuator front attachment (4).
2. Screw the front attachment (1, 2) onto the actuator front attachment (4). The engaging thread length must be at least 12 mm, which is the diameter of the thread.
3. Tighten the front attachment (1) with the lock nut (3) to 20 Nm.
4. Remove the safety pin (2) from the front attachment (1).
5. Install the actuator onto the front and rear attachments. Mount the safety pin (2) onto the front attachment (1). Mount rod (6) with safety pins (7) onto the rear attachments (5) and (8).

## 7 Commissioning

Only qualified personnel may start up the system.

The power supply must comply with the technical specifications.

1. Disconnect the power supply for the actuator before installation.
2. Make sure that the actuator is not under load or voltage.
3. Use suitable safety equipment.

## 8 Operation

 Avoid moving the actuator to the mechanical end position. Repeatedly moving the actuator to the mechanical end position can damage it or shorten its operating life.

 **WARNING** Load limit exceeded  
 Risk of injury  
 ▶ Observe the load limits specified in the technical data.

 **NOTICE** Load limit exceeded  
 Material damage to the actuator  
 ▶ Observe the load limits specified in the technical data.

The motor and surrounding components can become hot under high loads and during a high duty cycle.

Do not operate the brake separately when the actuator is under load.

## 9 Troubleshooting

 **WARNING** Live components  
 Risk of injury due to electric shock  
 ▶ Disconnect the devices from the supply voltage before carrying out any work on the drive or control unit.

### 4 Malfunction

Malfunction	Possible cause	Remedy
Greatly increased running noises	Motor, actuator, or nut defective	<ul style="list-style-type: none"> <li>▶ Stop operation immediately.</li> <li>▶ Send the actuator to Schaeffler immediately.</li> </ul>
Wobbling actuator movement	Excessive load	<ul style="list-style-type: none"> <li>▶ Stop operation immediately.</li> </ul>

If a malfunction cannot be rectified with the measures described, contact Schaeffler Service.

## 10 Maintenance

Maintenance work and repairs may only be carried out by qualified personnel.

1. Disconnect the power supply for the actuator before maintenance work and repairs.
2. Make sure that the actuator is not under load or voltage.
3. Use suitable safety equipment.

**⚠ DANGER**



### Risk of fatal injury from unauthorized reconnection of the power supply

Risk of fatal injury to persons in the hazard area due to moving parts or electric shock if the power supply is switched on without authorization during work on the system and causes the system to restart.

- Before starting work, switch off the system and secure it against reconnection.

### 📅 Maintenance plan

Activity	daily	monthly	every 6 months	annually
Check the device for visible damage	✓			
Remove any dust and dirt	✓			
Check attachments and tighten them if necessary		✓		
Check cables for damage and replace them if necessary		✓		
Check special equipment for visible damage and replace it if necessary		✓		
Functional test		✓		
Add a few drops of oil to the adjustment tube			✓	
Check labels				✓
Check electrical connections				✓

## 11 Disposal

Observe the local regulations for disposal.

As the actuator is principally made of steel and stainless steel, it may have some grease or oil inside. When disposed of, the motor and some accessories – such as limit switches and encoders – are treated as electronic scrap.

## 12 Technical data

All values for standard actuators are tested under the following conditions:

- Temperature +20 °C (+68 °F)
- Stabilized voltage
- Compression load

### 📅 Technical data, CAT, DC versions

Characteristic	Unit	CAT33		CAT32B		CAT33H	
Voltage supply	–	DC		DC		DC	
Voltage	V	12	24	12	24	12	24
Current consumption	A	18	9	18	9	18	9
			5 <sup>1)</sup>		5 <sup>1)</sup>		5 <sup>1)</sup>

Characteristic	Unit	CAT33	CAT32B	CAT33H
Type of protection <sup>2)</sup>	-	IP44, IP66	IP44, IP66	IP44, IP66
Rated push load	N	800 ... 3000	1000 ... 4000	400 ... 1200
Rated pull load	N	800 ... 3000	1000 ... 4000	400 ... 1200
Speed <sup>3)</sup> (full load to no load)	mm/s	5 ... 52	5 ... 52	17 ... 193
Stroke S	mm	100 ... 400	50 ... 700	100 ... 400
Retracted length L <sup>4)</sup>	mm	S + 150 / 158 / 189	S + 167 / 175 / 206	S + 150 / 158 / 189
Power consumption	W	-	-	-
Duty cycle	%	15	20	20
Ambient temperature	°C	-20 ... +50	-20 ... +50	-20 ... +50
Weight	kg	2.0 ... 2.7	2.0 ... 3.5	2.0 ... 2.7

- 1) for motor D24CW and P24CW
- 2) Type of protection IP20 if brake is used
- 3) Depending on the motor selected
- 4) Depending on the front attachment selected

7 Technical data, CAT, AC versions

Characteristic	Unit	CAT33			CAT32B			CAT33H		
Voltage supply	-	AC			AC			AC		
Voltage	V	120	230	400	120	230	400	120	230	400
Power consumption	W	98	92	80	98	92	80	98	92	80
Power consumption, braking	W	133.2	117.3	-	133.2	117.3	-	133.2	117.3	-
Current consumption	A	0.82	0.4	0.2	0.82	0.4	0.2	0.82	0.4	0.2
Current consumption, braking	A	1.11	0.51	-	1.11	0.51	-	1.11	0.51	-
Type of protection	-	IP20, IP54, IP55			IP20, IP54, IP55			IP20, IP54, IP55		
Rated push load	N	800 ... 3000			1500 ... 3500			500 ... 1200		
Rated pull load	N	800 ... 3000			1500 ... 3500			500 ... 1200		
Speed <sup>5)</sup> (full load to no load)	mm/s	5 ... 24			6.5 ... 32			20 ... 90		
Stroke S	mm	100 ... 400			50 ... 700			100 ... 400		
Retracted length L <sup>6)</sup>	mm	S + 150 / 158 / 189			S + 167 / 175 / 206			S + 150 / 158 / 189		
Duty cycle	%	30			30			20		
Ambient temperature	°C	-20 ... +50			-20 ... +50			-20 ... +50		
Weight	kg	2.0 ... 2.7			2.0 ... 3.5			2.0 ... 2.7		

- 5) Depending on the motor selected
- 6) Depending on the front attachment selected

## 12.1 Duty Factor

The permissible load depends on the duty factor, i.e., the load must be reduced if the duty factor is increased. The duty factor is defined as the time running under load in relation to the total cycle time.

f11 Determining the duty factor

$$D = \frac{N}{N+R} \cdot 100$$

D	%	Duty factor
N	s	Time running under load
N+R	s	Total cycle time
R	s	Rest time

**NOTICE**

**Duty factor exceeded**

Material damage to the actuator due to overheating



- Reduce running under load
- Extend rest time

5 Definition of duty factor

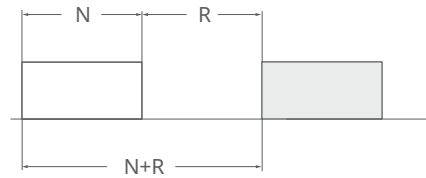

001C33F0

N	s	Time running under load
N+R	s	Total cycle time
R	s	Rest time

**DC versions**

The admissible load for DC actuators at a given duty cycle is expressed as a percentage of the maximum dynamic load-carrying capacity

8 Duty factor for DC versions at +20 °C (+68 °F)

Actuator	Max. duty factor at max. dynamic load
CAT33	15 %
CAT32B	20 %
CAT33H	20 %

**AC versions**

The diagrams show the maximum load as a function of the duty cycle.

The diagrams show how the actuators work when using different capacitors with single-phase motors E220C and E110C.

6 CAT33 AC: 120 V

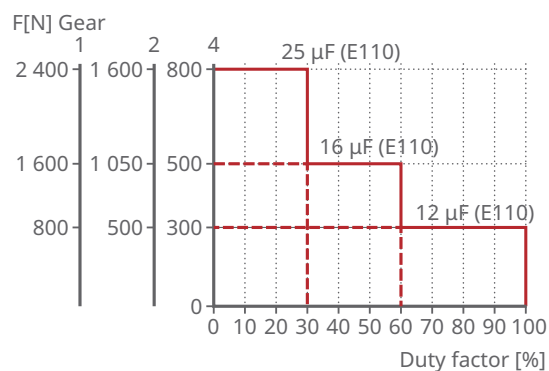

001C36D8

7 CAT33 AC: 230 V

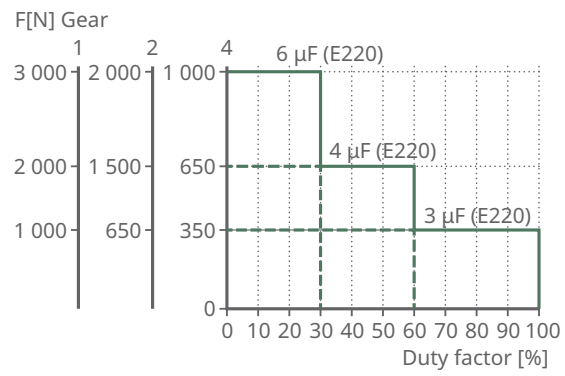

001C36D9

8 CAT32B AC: 120 V, 230 V

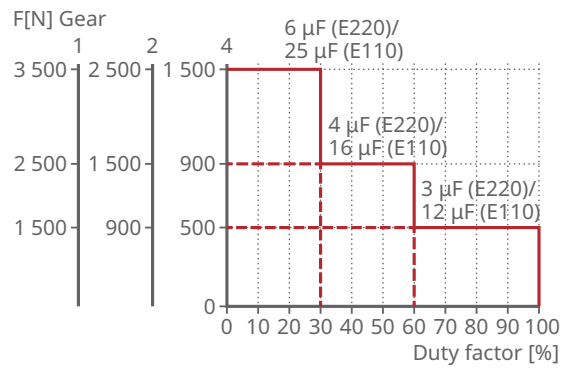

001C36DA

9 CAT33H AC: 120 V

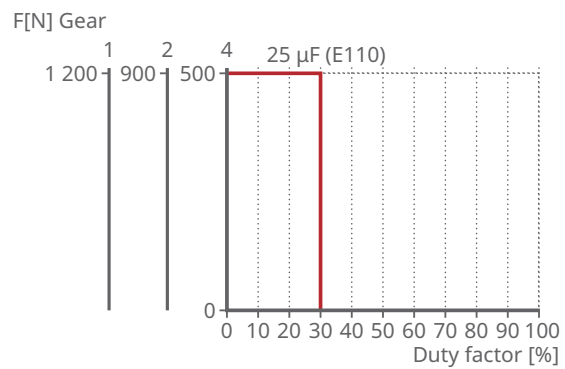

001C36DC

10 CAT33H AC: 230 V

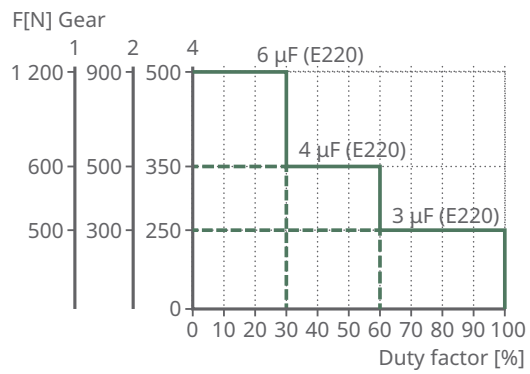

001C36DE

## 12.2 Circuit Diagrams

Complete installation instructions for the limit switch can be found in the separate installation instructions.

11 AC single-phase alternating current: 120 V, 230 V

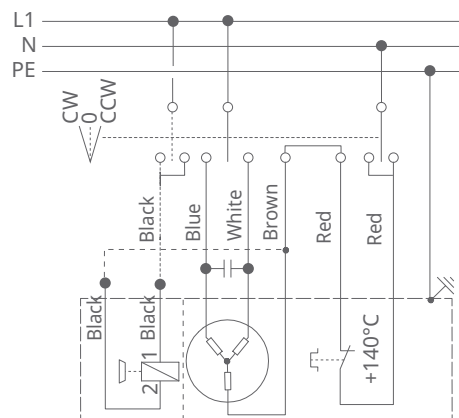

001D2216

12 AC three-phase alternating current: 400 V

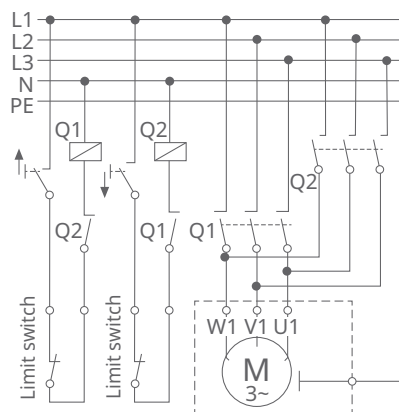

001D2286

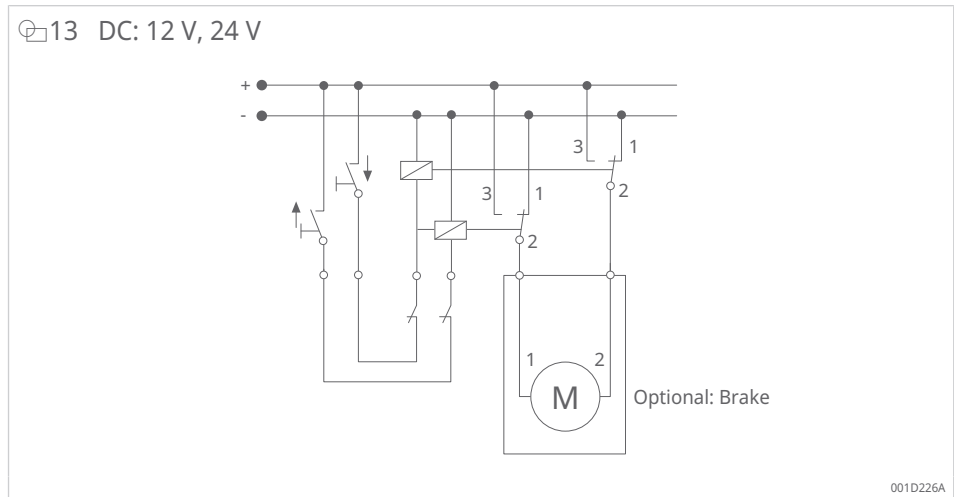

### 12.3 Two-channel Quadrature Encoder E2

The encoder is available for all motor types and thread pitches of the CAT module series.

The encoder consists of 2 parts:

- 1 rotating permanent magnet on the motor drive shaft.
- 1 printed circuit board (PCB) mounted on the opposite side of the motor.

The rotating permanent magnet has 4 poles (2N and 2S); during 1 motor revolution, 2 impulses are generated in each channel. The output signals of channels 1 and 2 are phase-shifted by  $\pm 90^\circ$ .

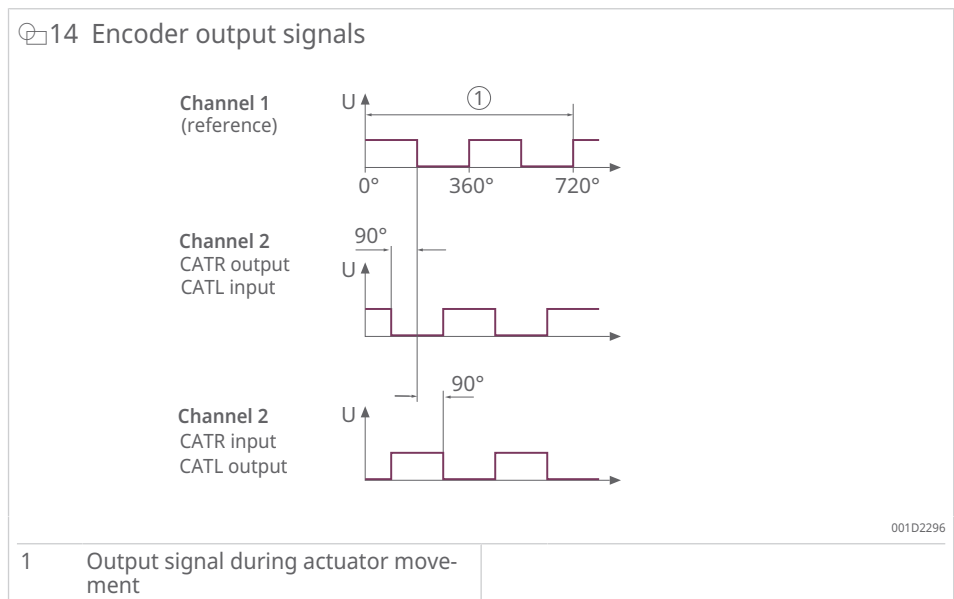

#### 9 Encoder movement resolution

Actuator	Gearbox option	Impulse at 1 mm stroke	Resolution per impulse
		-	mm
CAT33	1	16.67	0.06
	2	8.33	0.12
	4	4.17	0.24
CAT33H	1	4.00	0.25
	2	2.00	0.50
	4	1.00	1.00

Actuator	Gearbox option	Impulse at 1 mm stroke	Resolution per impulse
		–	mm
CAT32B	1	12.50	0.08
	2	6.25	0.16
	4	3.13	0.32

#### 10 Encoder operating conditions

Characteristic	Unit	Encoder E2
Ambient temperature	°C	–20 ... +50
Voltage supply	–	DC
Voltage ±5 %	V	+5 ... +24
Max. current sink capacity	mA	20

#### 11 Cable color coding according to DIN EN IEC 60757

Signal	Actuator installation		Color
Supply voltage	GND	–	Brown
	POS	–	White
Output signal channel <sup>1)</sup>	1	CATL	Green
	2		Yellow
	1	CATR	Yellow
	2		Green

<sup>1)</sup> The alternative cable colors for the output signals mean that the actuator was mounted on the right (CATR) or left (CATL). The cables are supplied with stripped ends without connectors.

#### 15 Encoder output signals

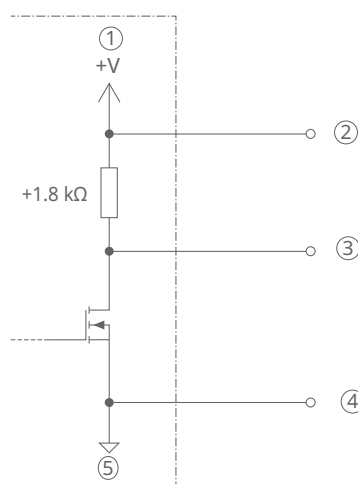

001C37EB

1	Encoder	2	POS supply voltage
3	Output signal	4	GND supply voltage
5	GND		

## 12.4 Declaration of incorporation

CAT |

<https://www.schaeffler.de/std/228C>

## 13 Replacement parts and accessories

### 13.1 Replacement parts

If you require additional information or replacement parts, please contact Schaeffler.

### 13.2 Accessories

- Limit switch
- Encoder E2



**Schaeffler Technologies AG & Co. KG**

Georg-Schäfer-Straße 30

97421 Schweinfurt

Germany

[www.schaeffler.de/en](http://www.schaeffler.de/en)

[info.de@schaeffler.com](mailto:info.de@schaeffler.com)

In Germany:

Phone 0180 5003872

From other countries:

Phone +49 9721 91-0

All information has been carefully compiled and checked by us, but we cannot guarantee complete accuracy. We reserve the right to make corrections. Therefore, please always check whether more up-to-date or amended information is available. This publication supersedes all deviating information from older publications. Printing, including excerpts, is only permitted with our approval.  
© Schaeffler Technologies AG & Co. KG  
BA 127 / 01 / en-US / 2026-04